



**USER MANUAL**

**Mobeye<sup>®</sup> WaterGuard**  
**CM2300FS**  
**Water floater sensor**

SW version 1.n

## CONTENT

<b>1.</b>	<b>General description</b>	<b>2</b>
<b>2.</b>	<b>Getting started</b>	<b>3</b>
2.1	Place a SIM card	3
2.2	Connect the water sensor to input 1	3
2.3	Place the batteries	4
2.4	Enter the program mode	4
2.5	Program at least one telephone number	4
2.6	Switching on/off	4
<b>3.</b>	<b>Use of input 2 and external power supply</b>	<b>5</b>
3.1	Using the input 2	5
3.2	Using external power	5
<b>4.</b>	<b>Extended options</b>	<b>6</b>
4.1	Program mode	6
4.2	The security code	6
4.3	Programming the settings by SMS	6
4.4	Possible General settings	7
4.4.1	Phone numbers	7
4.4.2	Identification text	7
4.4.3	Alarm notification type: SMS or SMS + call	7
4.4.4	Alarm text	7
4.4.5	Input type	7
4.4.6	Input delay time	8
4.4.7	Inactive time	8
4.4.8	Alarm repeat time	8
4.4.9	Test SMS text message	8
4.4.10	Power failure SMS message	8
4.5	List of SMS commands for configuration	9
4.6	Reset of system	9
<b>5.</b>	<b>Request overview of the settings and status</b>	<b>10</b>
5.1	Status request	10
5.2	Overview general settings	10
5.3	Overview phone numbers	10
<b>6.</b>	<b>Technical messages and status feedback</b>	<b>11</b>

## **Attention! Very important**

This user manual contains important guidelines for the installation and usage of the Mobeye® device as described in this manual. Please read these thoroughly before you start using the Mobeye® device!

In case of damage caused by disregarding the guidelines, the warranty expires.

The user must regularly check the proper functioning of the device. The manufacturer cannot be held liable for any damage caused by any incorrect use or incorrect functioning of the Mobeye® device.

### **Safety guidelines**

- The permitted ambient temperature during operation may not be exceeded (not lower than -10°C and not higher than 50°C).
- The device is intended for use in dry and clean places.
- Protect the device from moisture, heat and water splashing.
- The guidelines for the battery usage must be regarded.
- Do not expose the device to strong vibrations.
- Do not let it fall from height.
- Do not use in an environment where any inflammable gases, vapors or dust are present or could be present.
- The repairs of the device may only be carried out by people, trained for Mobeye® repair.
- In case the device must be repaired, only original replacement components may be used. The use of different parts may lead to damage of the Mobeye® device.

### **Use in accordance with the regulation**

The use of this device in accordance with the regulation is sending SMS text messages and making telephone calls after an alarm situation. Other usages are not permitted.

### **Battery recycling**

CR123 batteries, as used in the Mobeye WaterGuard, are classified as non-hazardous waste and can be recycled. Please take empty batteries to a nearest collection point.

## 1. GENERAL DESCRIPTION

The Mobeye WaterGuard is a battery operated GSM module used to send out an alarm after detection of a water based fluid, after a triggered input or - if external power supply is used- after a power failure.

The Mobeye WaterGuard is pre-programmed with standard action-reaction patterns. To change this behaviour please refer to chapter 4.

The factory settings of the Mobeye WaterGuard cause following reactions:

- In case of a water alarm, the Mobeye WaterGuard sends an alarm SMS text message and calls to the phone numbers as programmed. The SMS message contains the text 'Mobeye Water alarm'.
- As soon as no water is detected anymore, an SMS text message is sent to the set telephone numbers containing the text 'Mobeye Water Level OK'.
- In case the additional input is activated by a sensor, the Mobeye WaterGuard sends an alarm SMS text message and calls to the phone numbers as programmed by the user.
- In case the water sensor and/or the input remain in the alarm status, the Mobeye WaterGuard repeats sending the SMS alarm message every four hours.
- In case the batteries need to be replaced, the Mobeye WaterGuard sends a 'battery low' SMS text message to the administrator.
- In case an external power supply is used and a power failure occurs, the Mobeye WaterGuard sends a 'power failure' SMS text message to the administrator. In case the power is restored, the Mobeye WaterGuard sends a 'power restored' SMS text message to the administrator.

## 2. GETTING STARTED

To get started with the Mobeye WaterGuard at least the following steps need to be taken in following order:

1. Place SIM card (with PIN code 0000 or without PIN code)
2. Connect the water sensor to the unit
3. Place the batteries
4. Enter the program mode
5. Program at least one telephone number (administrators' number)
6. Arming/disarming the system

These steps are further explained in this chapter. After these steps the module will be operational.

### 2.1 PLACE A SIM CARD

Open the enclosure with the 4 screws and insert a SIM card into the module. Push the black cover outward slightly to open the holder. Before installing the SIM card should have PIN code "0000", or be free of a PIN code.

(A PIN code can be changed or removed by putting the SIM card in a mobile phone and change or remove the PIN in the security menu.)

**NB:** make sure the SIM card is inserted before the batteries are placed. In case of a SIM card change, please first remove the batteries (and remove any other external power supply).

### 2.2 CONNECT THE WATER SENSOR TO INPUT 1

Insert the 2 wires of the external water floater sensor through the hole of the enclosure to the inside part and next in the two connectors of **input 1** (press on the green pins for connecting the wires). It does not matter which wire is connected to which connector. If necessary the wires can be extended up to 5 meters using appropriate wire material.

Mount the floater to a fixed place in horizontal position with the moving part in open status. Mount the sensor at the height where the presence of water should be detected. In case the floater should be closed in normal situation (and be opened after water detection), the input type should be changed (please refer to paragraph 4.4.5).

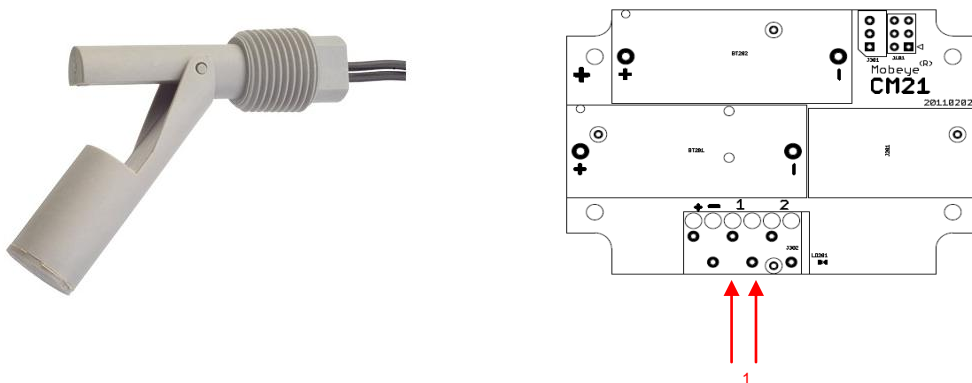

## **2.3 PLACE THE BATTERIES**

Place the two batteries (CR123) in the module. Use the +/- indication for the correct placement. The green LED will flash to indicate that the module is not configured (at least one telephone number should be programmed).

## **2.4 ENTER THE PROGRAM MODE**

Directly after placing the batteries, the Mobeye WaterGuard switches to the program mode. First the GSM module establishes network connection. During this time the LED flashes 2 sec. on/1 sec. off. Within 10-30 seconds the connection is established and the status LED starts flashing 1 sec. on/1 sec. off (or 'on' in case the first telephone number has been configured).

The Mobeye WaterGuard returns to the program mode by pressing the on/off button during 5 seconds, until the LED starts flashing (or turns to 'on').

As long as the unit is in the program mode, the status LED is on (or flashing 1 sec. on/1 sec. off if the module has no configuration). During the first 3 minutes, the GSM module remains open, ready to receive SMS commands. After 3 minutes a time-out occurs and the GSM module switches off in order to save the batteries. The unit returns to the low power operational mode.

## **2.5 PROGRAM AT LEAST ONE TELEPHONE NUMBER**

The Mobeye WaterGuard is able to send messages up to 5 telephone numbers. The first telephone number belongs to the administrator. Technical messages (like "battery low") are sent to the administrator only. Without the administrators' phone number, the Mobeye WaterGuard cannot not function.

When the WaterGuard is in initial (factory) status and the batteries are placed (so the LED is flashing), the administrators' number is programmed by calling the telephone number of the Mobeye WaterGuard using the administrators' phone. The unit will recognize this number and store it as administrator (telephone number 1). The administrator will receive a confirmation SMS text message including the security code. This code is needed to program the other settings in the unit.

NB: for this way of programming the number recognition in the administrator's phone must be 'on'. To program or change the administrators' number by SMS command, please refer to 4.4.1.

## **2.6 SWITCHING ON/OFF**

After the previous steps, the Mobeye WaterGuard is ready for use.

It is armed (switched on) automatically. The green LED blinks once in 3 seconds.

In order to switch off (disarm) the Mobeye WaterGuard:

- Press the on/ off button at the upper side for 1 second. The green LED switches off to indicate the armed status.

In order to switch on (arm) the Mobeye WaterGuard:

- Press the on/ off button at the upper side for 1 second. The green LED blinks once in 3 seconds (or permanently in case of an external power supply) to indicate the armed status.

### 3. USE OF INPUT 2 AND EXTERNAL POWER SUPPLY

#### 3.1 USING THE INPUT 2

It is possible to connect an external sensor to input 2. As a standard reaction after a triggered input, the Mobeye WaterGuard sends an SMS text message to the preset numbers and calls these numbers.

Insert the 2 wires of an external sensor through the hole of the enclosure to the inside part and next in the two connectors of input 1 (press on the green pins for connecting the wires). It does not matter which wire is connected to which connector. If necessary the wires can be extended up to 5 meters using appropriate wire material.

As default the input 2 is programmed as Normally Open (NO) contacts. This means the input is triggered in case the input is closed during at least 1 second. In case the contact should be Normally Closed (NC), please refer to paragraph 4.4.5. In case a sensor should be activated shorter or longer before evoking an alarm, please refer to 4.4.6.

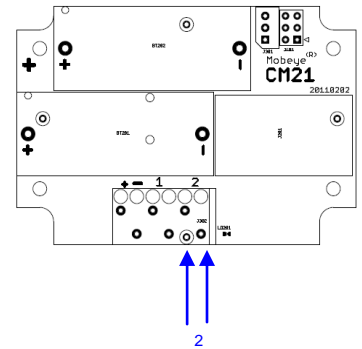

#### 3.2 USING EXTERNAL POWER

Although the Mobeye WaterGuard is designed to run on batteries, it is possible to use an external power supply. In this mode the module is always in connection with the GSM network and therefore always in program mode. In case the power fails, the batteries take over the functioning and the administrator is informed by an SMS text message. The module continues operating albeit in the low power mode. This means the GSM module switches off and only establishes network connection in case it needs to send out an alarm, test message or battery low alert.

Connect the external power adapter (or any other regulated 12VDC power supply) to the power input of the connector (press on the green pins for connecting the wires):

- V+ (black lead with white stripe) to “+”
- Ground (black lead) to “-”

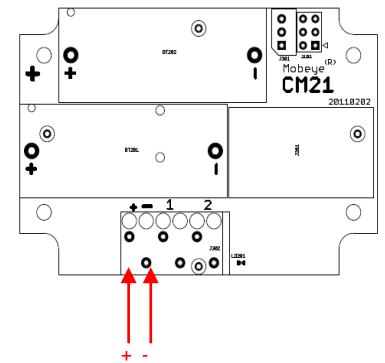

## 4. EXTENDED OPTIONS

To program the Mobeye WaterGuard, the GSM module must have network connection. In case only batteries are used, first switch the unit to the program mode. Next send SMS commands for the configuration.

All settings are stored and will be kept in the unit, even in case the power supplies are removed.

### 4.1 PROGRAM MODE

Directly after placing the batteries, the Mobeye WaterGuard switches to the program mode. First the GSM module establishes network connection. During this time the LED flashes 2 sec. on/1 sec. off. Within 10-30 seconds the connection is established and the status LED starts flashing 1 sec. on/1 sec. off (or 'on' in case the first telephone number has been configured).

The Mobeye WaterGuard returns to the program mode by pressing the on/off button during 5 seconds, until the LED starts flashing (or turns to 'on').

As long as the unit is in the program mode, the status LED is on (or flashing 1 sec. on/1 sec. off in case the module has no configuration). During the first 3 minutes the GSM module remains open, ready to receive SMS commands. After 3 minutes a time-out occurs and the GSM module switches off in order to save the batteries. The unit returns to the low power operational mode. In case the unit is connected to an external power supply, the WaterGuard has network connection all the time and the unit is in program mode all the time.

The program mode is interrupted by pressing the on/off button during one second until the LED switches off. The unit is switched off completely (disarmed).

### 4.2 THE SECURITY CODE

For configuration activities the security code of the Mobeye WaterGuard must be used. The initial security code is '1111'.

In this manual this code is referred to as <CODE>.

### 4.3 PROGRAMMING THE SETTINGS BY SMS

The settings are programmed by SMS text messages.

- Be sure the WaterGuard is in program mode (please refer to 4.1).
- Send an SMS message with following content:

**<CODE> <command>**

- Do not forget the space character between <PIN code> and <command>.
- The commands are case sensitive.
- Several commands may be combined in one SMS message (with a maximum of 160 characters) by placing a # between the commands.

**<CODE> <command1>#<command2> ..... #<commandN>**

The green LED blinks 3 times to indicate the successful configuration. In case of an incorrect command, the LED flashes 5 times.

In the complete scheme with SMS commands is listed
--



## 4.4 POSSIBLE GENERAL SETTINGS

This paragraph describes the general settings for the WaterGuard.

### 4.4.1 Phone numbers

The Mobeye WaterGuard is able to send alarm messages up to 5 phone numbers. The first telephone number (TEL1) belongs to the administrator. Only this number receives all system messages. The other phone numbers (including the administrator) only get the alarm messages.

To set or change telephone numbers:

SMS command 1<sup>st</sup> telephone number: **<CODE> TEL1:<tel. number>**

SMS command 2<sup>nd</sup> telephone number: **<CODE> TEL2:<tel. number>**

.... similar for TEL3...TEL5

To delete telephone numbers:

SMS command delete 1<sup>st</sup> telephone number: **<CODE> DEL1**

.... similar for DEL2...DEL5

In case a foreign number needs to be entered start with 00 follow by the country code (e.g. 0031612345678).

### 4.4.2 Identification text

It is possible to add a standard identification text (NAME) to all messages sent out by the Mobeye WaterGuard. The alarm messages are a combination of the name and the alarm text.

A user defined identification has a length of maximum 20 characters. The default identification text is 'Mobeye'.

SMS command identification text: **<CODE> NAME:<free text>**

### 4.4.3 Alarm notification type: SMS or SMS + call

As default behaviour, after an activated input the Mobeye WaterGuard notifies by SMS text message followed by a telephone call (beep signal). The combination of SMS text and the call increases the chance of getting the attention of the contact persons. It is possible to disable the call (OFF), so that only an SMS message will be sent. The default alarm notification type is ON (SMS + call).

SMS command alarm notification type: **<CODE> CALL:xxx**

### 4.4.4 Alarm text

Unique alarm texts can be programmed into the Mobeye WaterGuard. User defined texts have a maximum length of 20 characters.

Following default texts are programmed:

Water alarm <TEXT1>: Water alarm

Water level restored <TEXT2>: Water level OK

Triggered input 2 <TEXT3>: Alarm 2

SMS commands text 1: **<CODE> TEXT1:<free text>**

SMS commands text 2: **<CODE> TEXT2:<free text>**

SMS commands text 2: **<CODE> TEXT3:<free text>**

### 4.4.5 Input type

The input type defines the character of the inputs IN1 and IN2. This can be Normally Open (NO) or Normally Closed (NC). In case an input is set to NO, the alarm will be triggered as soon as the terminals of the input are closed. If the input is set to NC, the alarm is triggered in case the connection between the input terminals is broken. The default input type is set to NO.

SMS command input type for water sensor: **<CODE> TYPEIN1:xx**

SMS command input type for input 2: **<CODE> TYPEIN2:xx**

#### 4.4.6 Input delay time

The input delay time defines the time that the input are triggered before an alarm is initiated. If the input returns to the non-alarm status within the delay time, no alarm is sent. The time can be set between 0 and 999 seconds.

As default, the input delay time is set to 1 second.

SMS command alarm delay input water sensor: **<CODE> DELAY1:xxx**  
SMS command alarm delay input 2: **<CODE> DELAY2:xxx**

#### 4.4.7 Inactive time

The “inactive time” defines the time input 1 or input 2 is not active after an activation. In case the time is set to “0” (minutes), the input is active again immediately after returning to the non-alarm status. In case the time is set to e.g. 30 minutes, the input remains inactive for the first 30 minutes. In case the input is again (or still) activated after these 30 minutes, a new alarm message is sent.

The time can be set between 0 and 60 minutes. As default, the inactive time is set to “0”.

SMS command inactive time input water sensor: **<CODE> INACTIVEIN1:xx**  
SMS command inactive time input 2: **<CODE> INACTIVEIN2:xx**

#### 4.4.8 Alarm repeat time

In order to emphasize the urgency of the alarm messages, all alarms can be repeated. As long as the alarm status has not returned to the inactive status, the SMS alarm will be repeated after the ‘alarm repeat time’. The time can be set between 0 and 24 hours. As default the alarm repeat time is set to 4 hour.

SMS command alarm repeat time: **<CODE> REPEAT:xx**

#### 4.4.9 Test SMS text message

The Mobeye WaterGuard can send regular test SMS messages (‘keep alive’) to the administrator, to ensure the proper functioning of the unit. The test message function is only active in case the unit is armed.

The interval between the test messages can be set between 0 days (no test message) and 30 days. The default test interval is set to 0 (no test message).

SMS command interval test message: **<CODE> TEST:xx**

#### 4.4.10 Power failure SMS message

In case the Mobeye WaterGuard is powered externally and the power fails it sends an SMS text message to the administrator. The message is only sent in case the unit is armed. This message can be set to ‘OFF’. The default setting for the ‘power failure SMS text message’ is set to “ON”.

SMS command power failure message: **<CODE> POWERSMS:xx**

#### 4.5 LIST OF SMS COMMANDS FOR CONFIGURATION

Setting	SMS Command	Range	Default value
Change security code	INSTCODE:<xxxx>	0000..9999	1111
Set telephone number for alarm messages	TEL1:<tel number> .... TEL5:<tel number>		Empty
Delete telephone number	DEL1 .... DEL5		
Identification text	NAME: <text>	20 characters	Mobeye
Alarm notification type	CALL: <type>	ON, OFF	ON
Input type for water sensor	TYPEIN1:<type>	NO, NC	NO
Input type for input 2	TYPEIN2:<type>	NO, NC	NO
Delay on input 1, water sensor	DELAY1:<sec>	0..999 (sec)	1
Delay on input 2	DELAY2:<sec>	0..999 (sec)	1
Inactive time input 1, water sensor	INACTIVEIN1:<min>	0..60 (min)	0
Inactive time input 2	INACTIVEIN2:<min>	0..60 (min)	0
Alarm repeat time	REPEAT:hh	0..24 (hrs)	4
Alarm text after water detection	TEXT1:<text>	20 characters	Water alarm
Alarm text after end of water detection	TEXT2:<text>	20 characters	Water level OK
Alarm text input 2	TEXT3:<text>	20 characters	Alarm 2
Interval 'test SMS'	TEST:<days>	0..30 (days)	0
Power failure SMS	POWERSMS:<xx>	ON or OFF	ON

Examples:

Set phone number1 :            1111 TEL1:0612345678

Delete phone number1:           1111 DEL1

#### 4.6 RESET OF SYSTEM

To reset the Mobeye WaterGuard to its factory settings:

- Remove the batteries
- Press the outside button while entering the batteries. Keep it pressed for (about) another 5 seconds
- Release the button immediately after the LED starts to flash

After a successful reset, the status LED on the keypad will blink green to indicate that the module is not configured. The security code <CODE> is back to factory settings as well.

## **5. REQUEST OVERVIEW OF THE SETTINGS AND STATUS**

The programmed settings and status of the GSM detector can be received per SMS message. Before sending the request, make sure the unit is in the program mode (please refer to 4.1).

### **5.1 STATUS REQUEST**

The status of the Mobeye WaterGuard can be requested by sending an SMS with the content:

**<CODE> STATUS?**

Upon sending this request, the Mobeye WaterGuard returns the status to the originator of the request. The status message includes the ARMED / NOT CONFIGURED status of the Mobeye WaterGuard, the status of the inputs, power and batteries.

### **5.2 OVERVIEW GENERAL SETTINGS**

The general settings of the Mobeye WaterGuard can be requested by sending an SMS with the content :

**<CODE> SET?**

Upon sending this request, the Mobeye WaterGuard returns the list of programmed settings to the originator of the request.

### **5.3 OVERVIEW PHONE NUMBERS**

The list of telephone numbers can be requested by sending an SMS message with the content :

**<CODE> CALL?**

Upon sending this request, the Mobeye WaterGuard returns the list of programmed telephone numbers to the originator of the request.

## 6. TECHNICAL MESSAGES AND STATUS FEEDBACK

### Technical messages

In case of technical issues the administrator receives an SMS message. Possible technical messages are:

Message	Reason
Low batteries, external power supply OK	Power is available, batteries need to be replaced
No external power supply, batteries OK	No external power supply, batteries are capable to take over operation in low power mode
Low batteries, no external power supply	No external power supply, batteries need to be replaced
External power supply OK, batteries OK	The external power is restored (or the adapter is plugged in a socket), batteries do not need to be replaced
Message(s) missed due to Network/SIM failure	One or more SMS text messages couldn't be sent, due to a SIM card failure or GSM network failure.

When receiving one of the above mentioned technical messages, please take appropriate action as soon as possible. During the battery replacement, the SIM card does not have to be removed.

### Status feedback

Status	LED pattern	Required action
Module not configured	Blinking 1 second on / 1 second off	Configure at least one telephone number
Module is switched on, powered by batteries	1 flash every 3 seconds	No action required
Module is switched on, powered by an external source	On	No action required
Module establishes network connection to send an alarm message	Blinking 2 seconds on, 1 second off	Wait until the network connection is established and the message is sent
Module establishes network connection to get to program mode	Blinking 3 seconds on, 1 second off	Wait until the network connection is established before programming
No GSM connection	2 flashes every 3 seconds	Try the SIM card in any mobile telephone; replace SIM card using other telecom provider; try the module at another location
No valid SIM card or wrong PIN	3 flashes every 3 seconds	Try the SIM card in any mobile telephone; remove PIN code; check credit; replace SIM card
Successful programming action	Blinking 3 times	No action required
Faulty programming action	Flashing 5 times	Check SMS command
Low batteries	4 flashes every 3 seconds	Replace both batteries

## Technical specifications

GSM	:	Quad band EGSM, 850/900/1800/1900 MHz
Antenna	:	900/1800/1900 MHz
Batteries	:	2* CR123 (lithium)
Battery life in normal mode	:	>1 year
Ext. power connection	:	12 VDC (+/- 2 VDC) / min. 500 mA. (optional)
Power consumption low power	:	ca 50 µA. stand-by / max. ca. 500 mA
Power consumption 12V	:	ca 50 mA. stand-by / max. ca. 500 mA
Dimensions	:	80 x 60 x 40 mm
Ambient temperature	:	-10 °C until +50 °C

This manual is published by Mobeye®.

All rights, the translation included are reserved. Any reproduction, either photocopy, microfilm or saved in an automated data dictionary, only after written approval of the Publisher. Reprinting, even in summary, is prohibited.

This user manual meets the technical requirements at the moment of printing. Changes in technology and equipment are reserved.

© Copyright 2013 by Mobeye, version CM2300FSNL130331



## Declaration of Conformity

Herewith we, Mobeye, declare that the product

**Mobeye CM21 telemetry module**

And the derived products

**CM2000, CM2100, CM2200, CM2300,  
CM2300FS, CM2400, CM2500**

are in compliance with the essential requirements of the following European standards / EU Directives:

**Directive 73/23/EEC** (low voltage directive)

**Directive IEC/EN 50130** Electromagnetic compatibility

**Directive 1995/5/EC R&TTE** (Radio & Telecommunications Terminal Equipment)

The conformity with the essential requirements of 1995/5/EC has been verified against:

**ETSI EN 301 489-1 V1.5.1**

**ETSI EN 301 489-7 V1.2.1**

**ETSI EN 301 511 V9.0.2**

**CENELEC EN 60950:2001**

Mobeye B.V., Poeldonkweg 5, 5216 JX 's-Hertogenbosch, The Netherlands

Name: J.P.K. van de Vijver,

Position: General Manager

Date: 31 maart 2013